

FOF-ROL

OFF-LINE FILTERS



MATERIALS

Head and covers: Aluminium alloy
Bowl: Steel
Element Holder:
Polyamide FOF24
Alluminium Alloy FOF3+ and FOF4+
Seals: NBR Nitrile (FKM Fluoroelastomer on request)
Indicator housing: Brass

PRESSURE

Max. working: 1 MPa (10 bar)
Collapse, differential for the filter element (ISO 2941):
1MPa (10 bar)

BYPASS VALVE

Setting: 150 kPa (1,5 bar) \pm 10%

WORKING TEMPERATURE

From -25° to +110° C

COMPATIBILITY (ISO 2943)

Full with fluids: HH-HL-HM-HV-HTG
(according to ISO 6743/4)
For fluids different than the above mentioned,
please contact our Customer Service



HYDRAULIC DIAGRAM

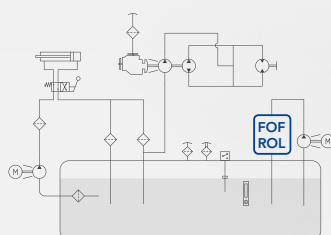

Is this datasheet the latest release? Please check on our website.



FOF

OFF-LINE FILTERS

ORDERING AND OPTION CHART

F	O	F	COMPLETE FILTER FAMILY						FILTER ELEMENT FAMILY	E	R	F	
			SIZE & LENGHT	24	34	36	41	44	SIZE & LENGHT				
			PORT TYPE										
			B = BSP thread	B	-	-	-	-					
			N = NPT thread	N	-	-	-	-					
			S = SAE thread	S	-	-	-	-					
			F = SAE flange 3000 psi	F	F	F	F	F					
			PORT SIZE										
			12 = 1" 1/2	12	-	-	-	-					
			16 = 2"	-	16	16	-	-					
			20 = 2"1/2	-	20	20	-	-					
			24 = 3"	-	-	-	24	24					
			32 = 4"	-	-	-	32	32					
			BYPASS VALVE										
			W = without bypass	W	W	W	W	W					
			F = 150 kPa (1,5 bar)	F	F	F	F	F					
			SEALS						SEALS				
			N = NBR Nitrile	N	N	N	N	N					
			F = FKM Fluoroelastomer	F	F	F	F	F					
			FILTER MEDIA						FILTER MEDIA				
			FA = fibreglass 5 µm(c) β>1.000	FA	FA	FA	FA	FA					
			FB = fibreglass 7 µm(c) β>1.000	FB	FB	FB	FB	FB					
			FC = fibreglass 12 µm(c) β>1.000	FC	FC	FC	FC	FC					
			FD = fibreglass 21 µm(c) β>1.000	FD	FD	FD	FD	FD					
			CC = impregnated cellulose 10 µm β>2	CC	CC	CC	CC	CC					
			ME = metal wire mesh 60 µm	ME	ME	ME	ME	ME					
			WR = water removal *	WR	WR	WR	WR	WR					
			CLOGGING INDICATOR**										
			03 = port, plugged	03	03	03	03	03					
			5B = visual differential 130 kPa (1,3 bar)	5B	5B	5B	5B	5B					
			6B = electrical differential 130 kPa (1,3 bar)	6B	6B	6B	6B	6B					
			7B = indicator 6B with LED	7B	7B	7B	7B	7B					
			T0 = elect. diff. 130 kPa (1,3 bar) with thermostat 30°C	T0	T0	T0	T0	T0					
			ACCESSORIES										
			W =without accessory	W	W	W	W	W					
			M = magnetic core	M	M	M	M	M					
			ACCESSORIES										
			W =without accessory	W	W	W	W	W					
			B = mounting brackets	B	B	B	B	B					



ROL

OFF-LINE FILTERS



ORDERING AND OPTION CHART

R	O	L	COMPLETE FILTER FAMILY			FILTER ELEMENT FAMILY	C	R	C
			SIZE & LENGHT	240	340	SIZE & LENGHT			
			FILTER MEDIA			FILTER MEDIA			
			FT = fibreglass 5 µm(c) β>1.000	FT	FT				
			FC = fibreglass 7 µm(c) β>1.000	FC	FC				
			FD = fibreglass 12 µm(c) β>1.000	FD	FD				
			FV = fibreglass 21 µm(c) β>1.000	FV	FV				
			CD = impregnated cellulose 10 µm β>2	CD	CD				
			MS = metal wire mesh 60 µm	MS	MS				
			WR = water removal *	WR	WR				
			SEALS			SEALS			
			1 = NBR Nitrile	1	1				
			2 = FKM Fluoroelastomer	2	2				
			BYPASS VALVE						
			S = without bypass	S	S				
			F = 150 kPa (1,5 bar)	F	F				
			PORT TYPE						
			B = BSP thread	B	-				
			N = NPT thread	N	-				
			S = SAE thread	S	-				
			F = SAE flange 3000 psi	F	F				
			PORT SIZE						
			7 = 1" 1/2	7	-				
			9 = 2" 1/2	-	9				
			CLOGGING INDICATOR **						
			03 = port, plugged	03	03				
			5B = visual differential 130 kPa (1,3 bar)	5B	5B				
			6B = electrical differential 130 kPa (1,3 bar)	6B	6B				
			7B = indicator 6B with LED	7B	7B				
			T0 = elect. diff. 130 kPa (1,3 bar) with thermostat 30°C	T0	T0				
			ACCESSORIES						
			S =without accessory	S	S				
			M = magnetic core	M	M				
			ACCESSORIES						
			S =without accessory	S	S				
			B = mounting brackets	B	B				

NOTES

* Water removal media, see "Hydro dry" chapter

** When the filter is ordered with FKM seals, the first digit of the indicator code is a letter (please see Clogging Indicator Chapter for further details)

INSTALLATION DRAWING

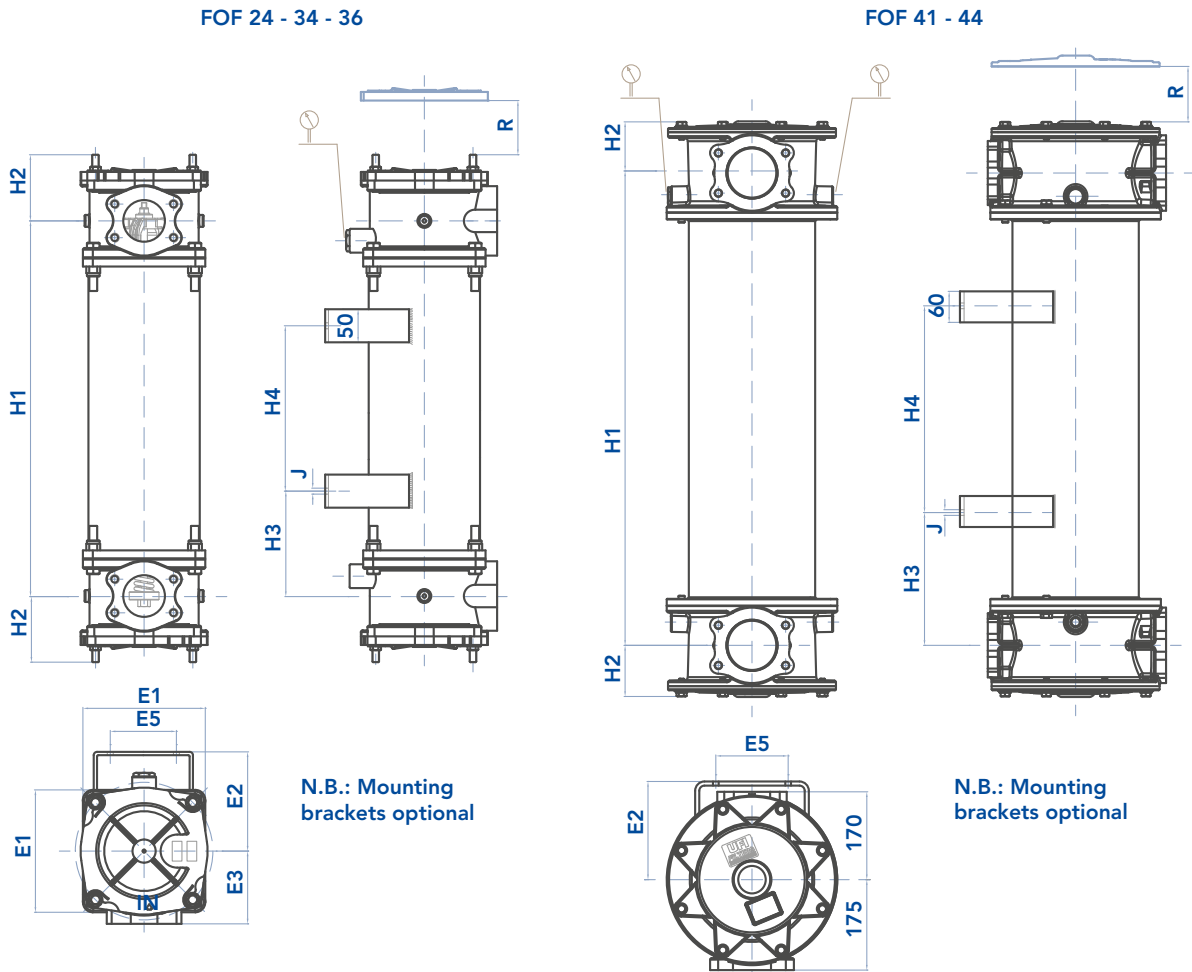

FILTER HOUSING

	PORT SIZE	E1	E2	E3	E5	H1	H2	H3	H4	J	R	kg
FOF24 ROL240	1" 1/2	150	132	90	70	513	93	130	250	9	580	18,0
FOF34 ROL340	2" - 2" 1/2	185	150	110	100	568	100	135	250	9	620	22,0
FOF36	2" - 2" 1/2	185	150	110	100	770	100	165	250	9	820	27,9
FOF41	3" - 4"	-	190	-	140	420	99	160	100	11	600	38,4
FOF44	3" - 4"	-	190	-	140	1.180	99	340	500	11	1.360	66,4

FOF-ROL

OFF-LINE FILTERS



MAINTENANCE

The best time to change your filter element is just before it reaches its maximum dirt-holding capacity. For this reason, we recommend to monitor the pressure of the hydraulic oil flowing through the filter with a clogging indicator. When it is time to change the filter element, switch off the system before opening the filter housing. Unscrew the cover of the filter head and remove the spring (to be hold) and the dirty filter element. Remove the handle. Replace the filter element with an original

UFI one, verifying the part number on the filter label or on the catalogue. Check the gaskets conditions and replace if necessary. Reassemble the handle on the element and insert it into its seat, handling with care and cleanliness. Replace the cover on the filter head with the screw. We recommend the stocking of a spare UFI filter element for timely replacement when required.

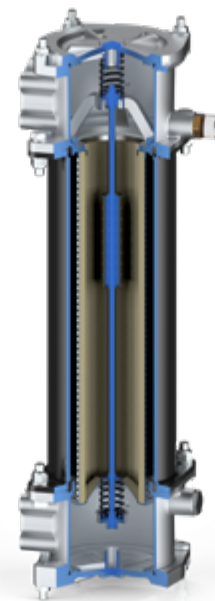

DISPOSAL OF FILTER ELEMENTS

The used filter elements cannot be cleaned and are classified as "Dangerous waste material". They must be disposed according to local laws by authorized Companies.

Verify that the Company you choose has the expertise and authorization to dispose this type of waste material.

FILTER ELEMENT

	A	B	C	KG	Media F+	AREA (cm ²)	
						Media C+	Media M+
ERF24 CRC240	72	106	465	1,50	9.700	11.800	3.670
ERF34 CRC340	92	126	480	2,20	12.800	15.400	5.250
ERF36	92	126	680	3,00	18.200	19.500	7.700
ERF41	157	203	330	3,90	17.900	22.100	6.400
ERF44	157	203	1.090	13,00	60.000	74.000	21.800

PRESSURE DROP CURVES (Δp)

The "Assembly Pressure Drop (Δp)" is obtained by adding the pressure drop values of the Filter Housing and of the Clean Filter

Element corresponding to the considered Flow Rate and it must be lower than 50 kPa (0,5 bar).

FILTER HOUSING PRESSURE DROP
(mainly depending on the port size)

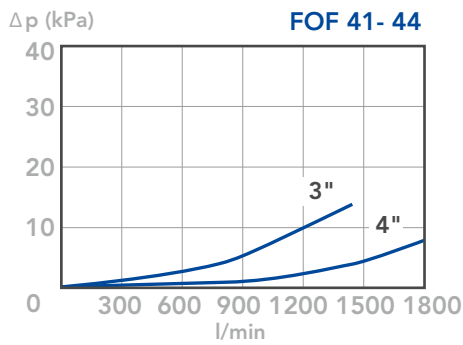
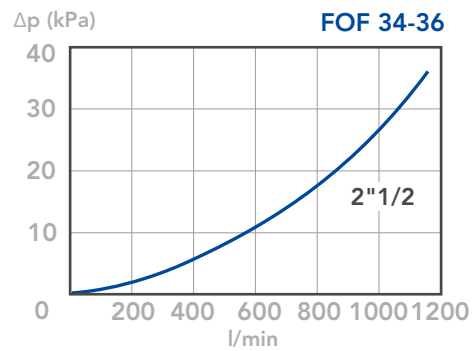
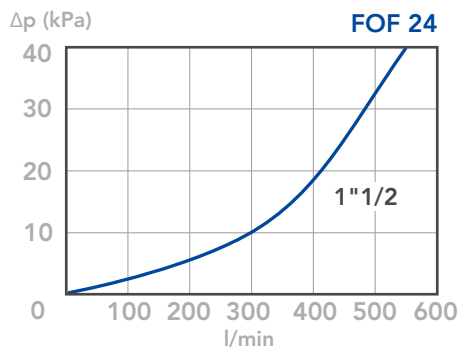

CLEAN FILTER ELEMENT PRESSURE DROP WITH F+, CC AND ME MEDIA
(depending both on the internal diameter of the element and on the filter media)

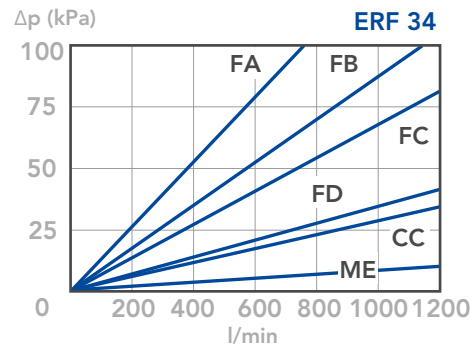
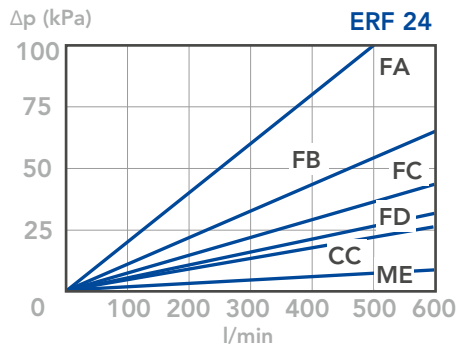

FOF-ROL

OFF-LINE FILTERS

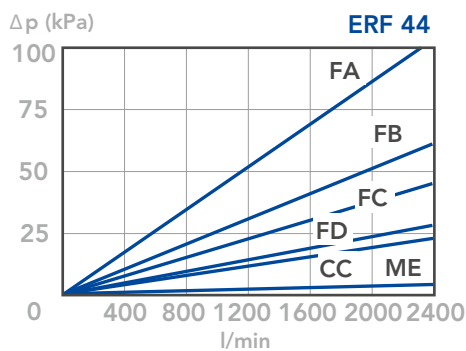
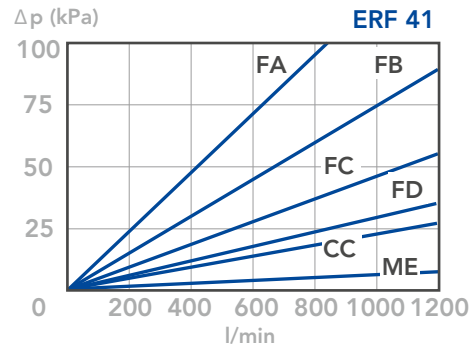
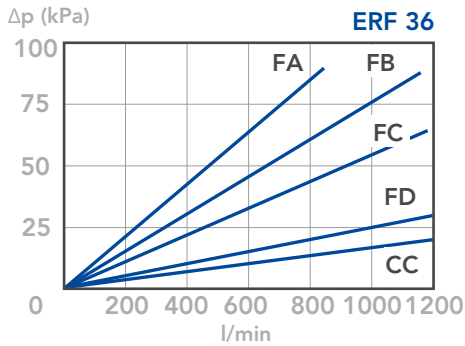

BYPASS VALVE PRESSURE DROP

When selecting the filter size, these curves must be taken into account if it is foreseen that any flow peak is to be absorbed by the bypass valve, it also must be of proper configuration to avoid pressure peaks. The valve pressure drop is directly proportional to fluid specific gravity.

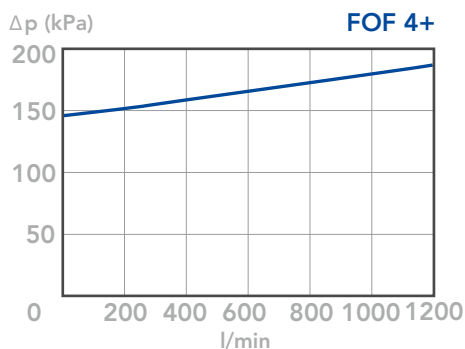
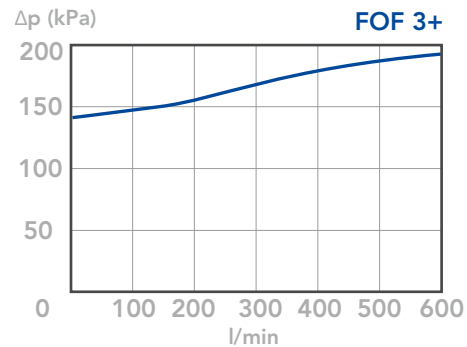
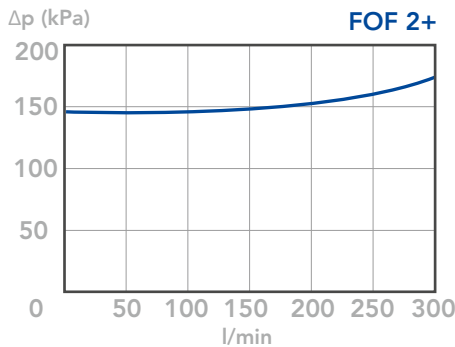

N.B.

All the curves have been obtained with mineral oil having a kinematic viscosity 30 cSt and specific gravity 0,86 Kg/dm³; for fluids with different features, please consider the factors described in the first part of this catalogue. All the curves

are obtained from test done at the UFI HYDRAULIC DIVISION Laboratory, according to the specification ISO 3968. In case of discrepancy, please check the contamination level, viscosity and features of the fluid in use.